

Platform Entry Gate Installation and Maintenance Instructions



Leask Engineering Ltd | 3442 State Highway 26 | Tātuanui | Morrinsville 3374
+64 7 889 7769 www.leask.co.nz

Contents

Introduction	3
Kit Components.....	4
Exploded Diagram	5
General Dimensions.....	6
Other Requirements (not supplied).....	6
Tools.....	6
Galvanised General Purpose Medium Pipe	6
Safety Requirements.....	7
Installation	8
Step 1: Check available operating height/Shorten the post.....	8
Step 2: Determine the post position.....	9
Step 3: Secure the post base.....	10
Step 4: Secure the post top.....	10
Step 5: Check free movement.....	11
Step 6: Attach the chain slots	11
Step 7: Attach the gate and chain.....	11
Maintenance	12
Wire Rope Replacement in situ	12
Step 1: Lift the weight to the top.....	12
Step 2: Remove the pulley	13
Step 3: Remove the wire rope	13
Step 4: Attach the new rope and reassemble.....	13

Introduction

The Leask Platform Entry Gate provides a secure backstop for the last cow on the milking platform. The gates are easy to install in an existing dairy shed and can be operated from the pit or on the platform.

- Up to 1800mm clearance
- Quiet and low maintenance operation
- Easy pull operation from the pit or platform
- Counterweighted to rise to open position when released
- Acetal rollers on stainless bolts and bearings
- Pivoting mast
- Hot dipped galvanised
- Wire rope can be replaced in situ

Since the early days of design, our platform entry gate has evolved and developed, and recent design changes have seen further significant improvements.



Kit Components

Item No.	Description	Quantity per gate
1	Chain Catch	2
5	M10 x 65 Masonry Screw Bolts	4
17	Chain	1
20	Gate Pin	1
25	Assembled Mast	1
30	Gate	1

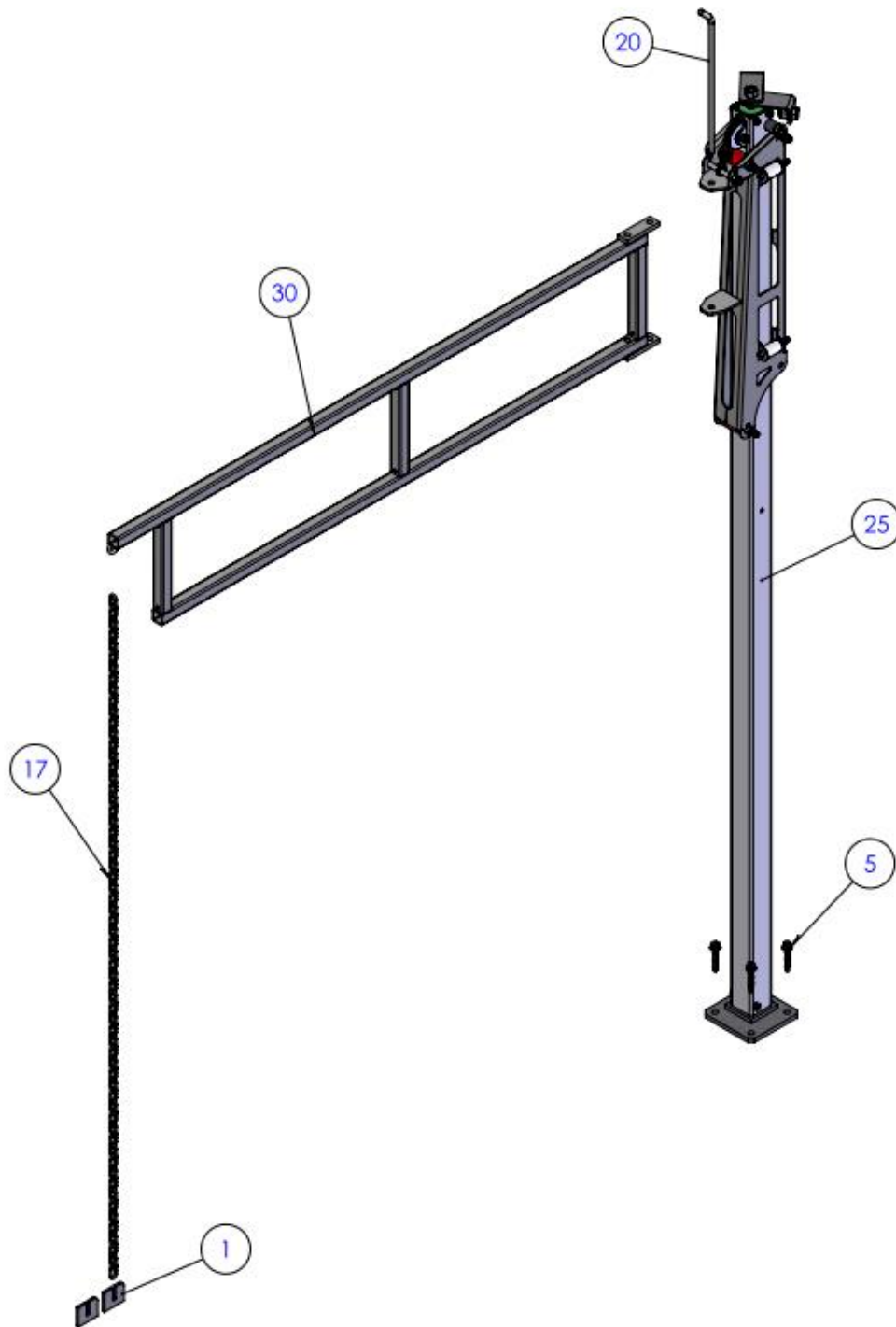

Fig 1. Kit Components

Exploded Diagram

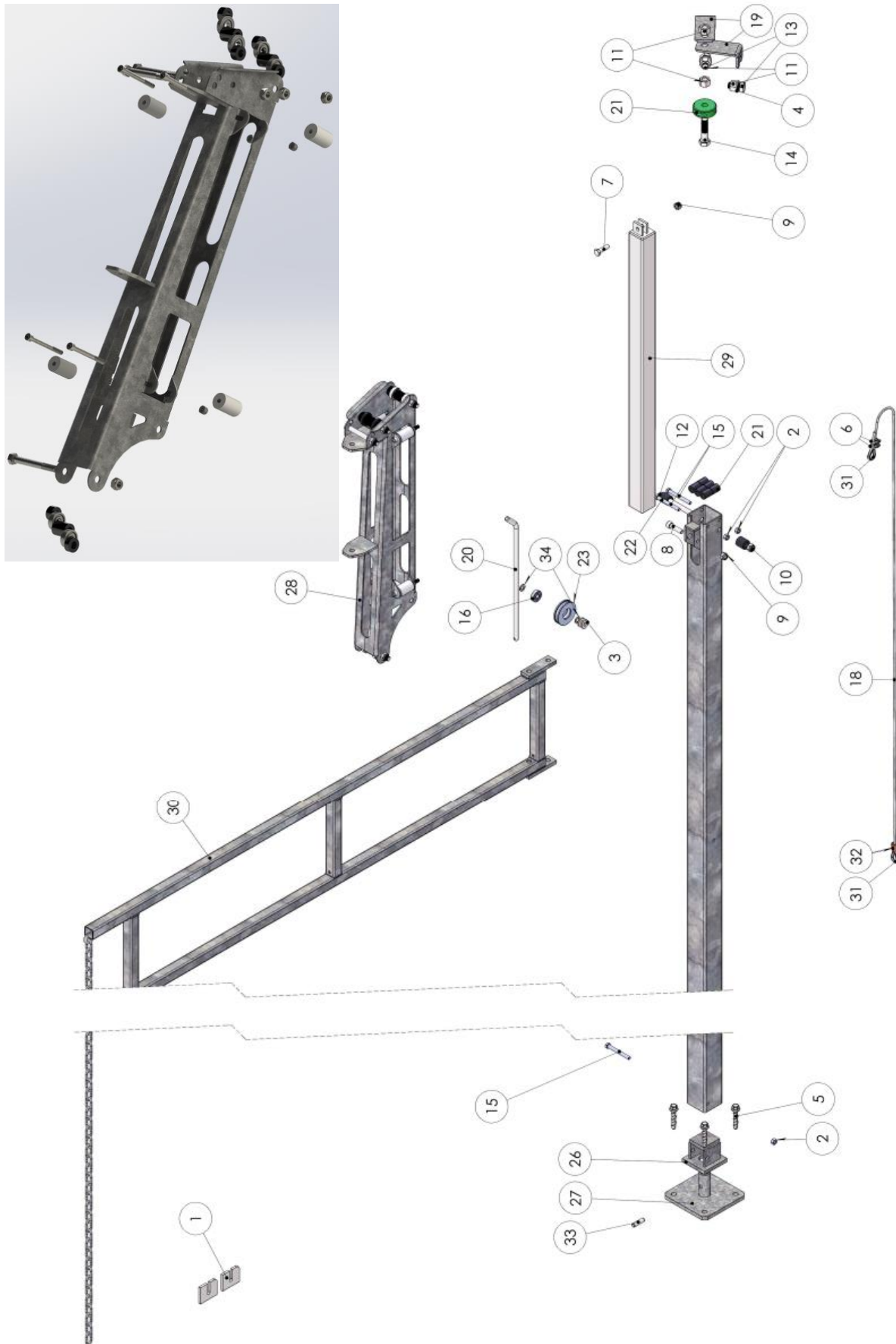
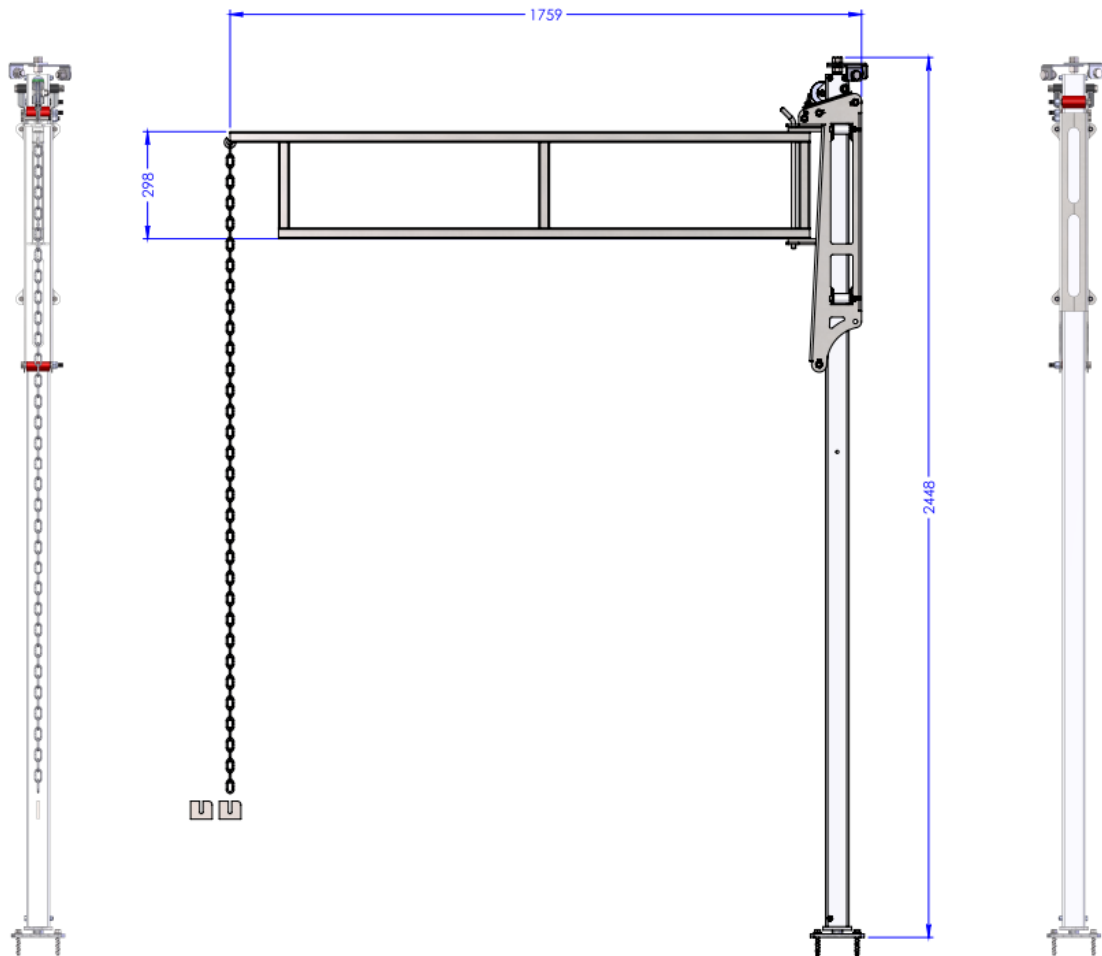

Fig 2. Exploded Diagram

General Dimensions



Weight 48.5KG

Fig 3. General Dimensions

Other Requirements (not supplied)

Tools

Marker	Grinder with cutting disk for steel
Spirit Level	Masonry Drill with 10mm drill bit
Arc welder	G clamp or similar
Hammer	Measuring Tape
13 and 24mm spanners (2 of each)	2.5 (or 3.2) welding rods
Centre Punch	Wire Brush
Paint and painting equipment	Square
9mm steel drill bit	Drill

Galvanised General Purpose Medium Pipe

20NB – sufficient length for 2 top props to the nearest rafter(s).

50NB – sufficient to bridge between the rafters if extra support is needed.

Safety Requirements

These installation instructions provide guidance for the correct installation of the Platform Entry Gates and are intended to be used by qualified and experienced site engineers, who are competent and fit to do the job safely. Local or site specific health and safety legislative requirements are not detailed within. Installers must adhere to all local health and safety legislation. It is the responsibility of the personnel on site to ensure the health and safety of everyone on and around your worksite, including workers, clients and members of the public. Within New Zealand, the Health and Safety at Work Act 2015 applies. If you have any queries or concerns regarding safe working practices, please contact your supervisor, site foreman/manager or local safety advisor before proceeding.

Leask Engineering is not responsible for the results of any action taken on the basis of information in this document, or for any errors or omissions. The following list is not exhaustive, but is intended as a quick guide.

Ensure:

- The worksite remains safe
- You are aware of the site hazards and controls implemented
- You report accidents or near misses in the required timeframes
- Personal protective equipment is worn in the correct manner (head, eyes, ears, hands, feet), relative to site hazards and/or other hazards
- Tools and equipment
 - are right for the job
 - have been tested and visually examined by a competent person
 - guards are secure and in good repair
 - safety devices are operating correctly
- All operators are trained and competent
- Electrical cables are within test date, and are routed to ensure safe working practices
- The work area is fenced off from the public
- Suitable steps or a platform are available (600mm should suffice but depends upon roof height)
- Proper manual lifting techniques are used to avoid injury
- Appropriate first aid and fire extinguishing equipment is at hand
- Safe work procedures associated with welding or grinding hot works (welding flashes, fumes, sparks, burns, fire) are followed

Note: The post is 40kg (without the gate), therefore it is recommended that 2 people lift and position this item to ensure safe working practices.

Installation

The Leask Platform Entry gate has been purposely designed for quick and easy installation. Please follow these instructions carefully, incorrect installation may shorten the lifespan of the gate, or make the gate more difficult to operate.

Step 1: Check available operating height/Shorten the post

Measure the distance from the concrete to the roof where the post is to be situated. The Entry Gate has been assembled with an overall height of 2448mm (see Fig 1) which can be fitted under a 2475mm roof.

If your available height is less than 2475mm, the mast will need to be shortened accordingly, as detailed below.

- Remove the bottom M8 bolt and nut, and slide out the pivot base (rubber cushions may also fall out).
- Calculate how much the post needs to be shortened e.g. if your roof height is 2350mm, shorten the post by 125mm (your available height – 2475).
- Mark a cut line and cut the post square. Remove any burrs.
- Mark and centre punch the position for a new 9mm diameter hole, 23mm from the new end and 13mm from the face (copy the original hole position). Drill the hole through 2 walls.
- Ensure the rubber cushions are reinserted into the post, reinsert the pivot base and secure with the M8 bolt and nut.
- Adjust (make shorter) the wire rope by the same measurement. Keep the wire rope grips close to the thimble to avoid fouling the plastic pulley. Do not cut the wire rope until you are sure all final adjustments have been made.

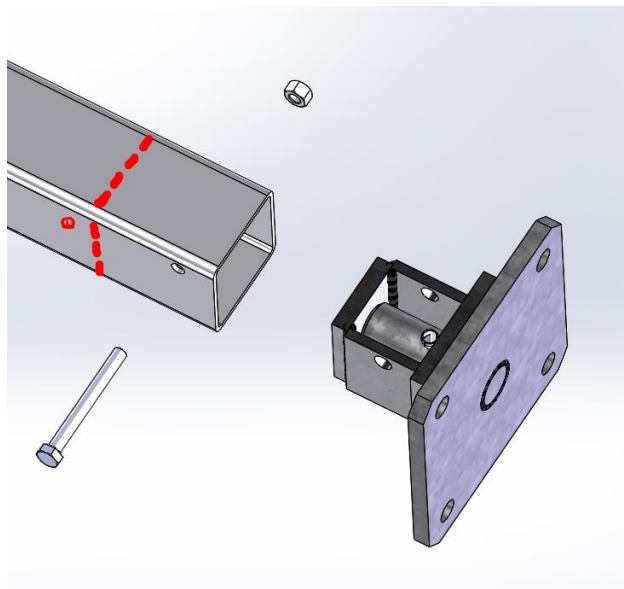

Fig 4. Shorten the post

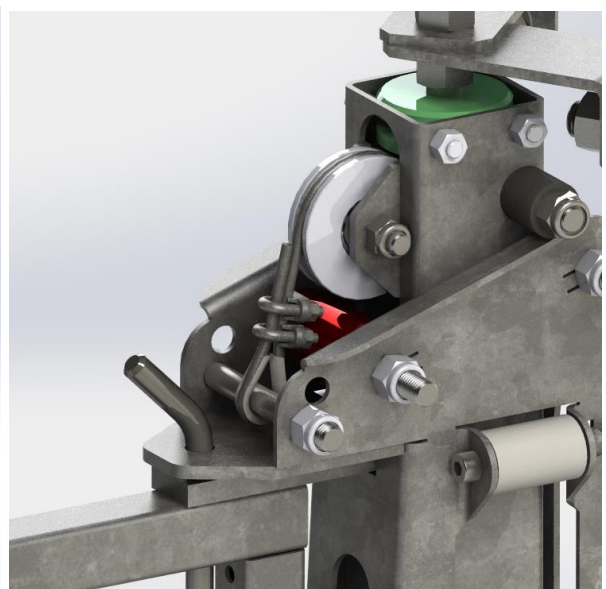

Fig 5. Shorten the wire rope

Step 2: Determine the post position

The post is to be positioned behind the breast rail as shown below, in an appropriate position to restrain the last cow.

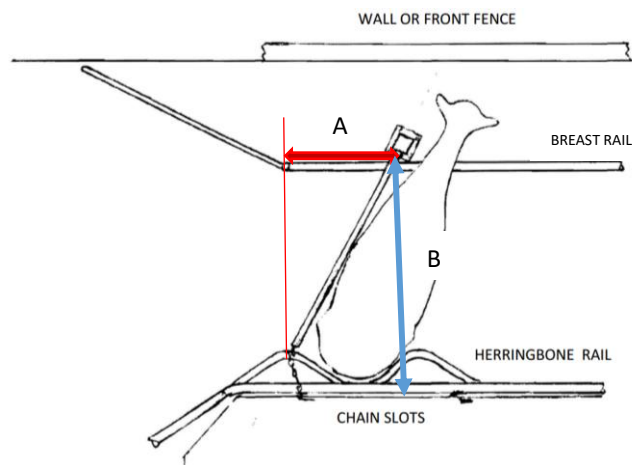

Fig 6. Plan view of gate position

The following table details the approximate distance from the centre of the post to the centre of the last herringbone (A) and typical distance from the pit edge (B):

Cup Centre Distance	Distance (A)
660	360
700	400
760	460
800	500
900	600
	Distance (B)
Typical Pit Edge to Base Plate Edge	1630

- If an adjustable breast rail is fitted, the post should be positioned far enough back to enable the breast rail to be pushed back fully (widest operating position). The pivot post will typically be 1630mm from the pit edge to the edge of the base plate.
- It may be necessary to move the post to an alternative position to avoid rafters etc.
- If feed troughs extend further than the last cow, a 180mm diameter hole may have to be cut in the trough through which the gate post will be centrally mounted.
- Allow an extra 90mm between the **centre** of the post and the breast rail, to enable the slide to come down past the breast rail, and for the post to pivot in this position.

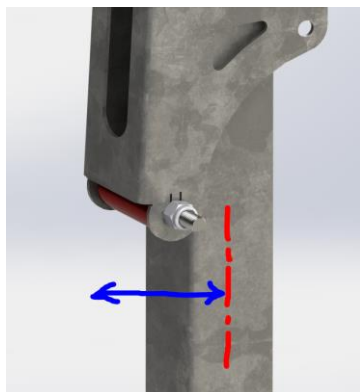

Fig 7a & 7b. Clearance at the breast rail for the slide

Fig 8. Photo showing a typical cut out in a feed trough

Step 3: Secure the post base

Place the post in the desired position. One person should hold the post plumb in both directions while the other person drills one 10mm diameter hole 75mm deep (through one of the base plate holes). Secure the base with one masonry screw bolt.

Note: The post rotates on the base and can also tilt in any direction until secured at the top. Do not let go until the post is secured upright.

Use a G clamp and a wooden spacer block to clamp the post securely to the breast rail. Adjust until the post is plumb in both directions.



Fig 9. Post clamped in position

Step 4: Secure the post top

Weld 20NB galvanised pipe to the M16 bolt heads, and weld the other end of the 20NB galvanised pipe to the rafters at an angle which supports the post in all directions. If the rafters are wooden, bolt the supports to the rafters. In some cases it may be necessary to span between 2 rafters with 50NB pipes, to which the entry gate props can be attached. Some mounting examples shown below:



Figs 10 & 11. Post Diagonal supports

Step 5: Check free movement

Remove the supporting G clamp and wooden spacers. Check all parts are free to move - pull the slide down and return it gently to the top again and rotate the post 360°.

Note: If there is a significant fall in the concrete, the low side of the base plate may need to be packed up to enable the post to pivot freely.

When you are satisfied the post is in the proper position and plumb, drill the remaining 3 bolt holes in the base plate and fix tightly with the masonry screw bolts.

Step 6: Attach the chain slots

Weld the chain slots to the breech (herringbone) rail as shown below.



Fig 12. Chain slots

Step 7: Attach the gate and chain

Pull the slide down to waist height. Place a G clamp on the post above the slide (to keep it from rising again). Place the gate into position on the slide as shown and attach with the pin.

Note: Do not use the outer hole – this was for an earlier version of gate. The gate must be fixed solid on the slide (not pivoting).

Attach the chain to the hook on the end of the gate.

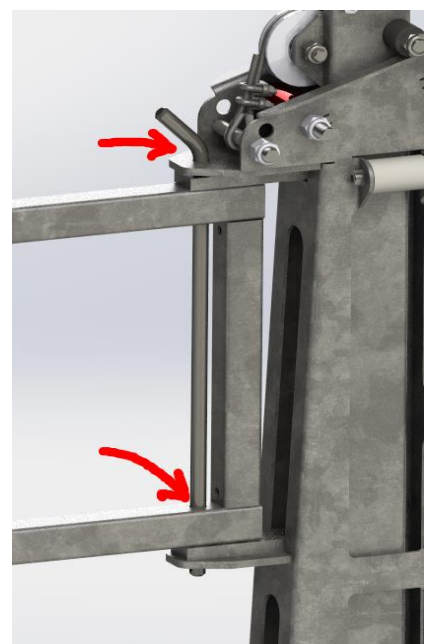

Fig 13. Gate mounting position

Maintenance

Do not lubricate the rollers or the weight inside the post as the lubricant could attract dust and make it stick.

It should take approximately 10kg force to pull the gate down. If the gate becomes hard to pull down (and slow to rise), remove and clean the rollers and axle bolts.

Every couple of months check the wire rope is tracking properly on the pulley, and that there is no fatigue showing in the wire rope. Replace the wire rope as necessary. If the wire rope breaks the post will need to be taken down to be able to remove the weight and wire rope. If so, follow the installation instructions in reverse order. If the wire rope is still attached to the weight, it can be replaced as detailed below:

Wire Rope Replacement in situ

Step 1: Lift the weight to the top

Pull the gate down until it is in its lowest position, the weight will now be in the highest possible position inside the post. Place a pin or screwdriver through the service hole to support the weight



Fig 14. Gate lowered



Fig 15. Service Hole

The weight should now be at the correct height for access to the weight/wire rope bolt and nut.

Step 2: Remove the pulley

Remove the cap screw, nut and washers which are retaining the pulley and bearing. Check the bearing and replace if necessary.

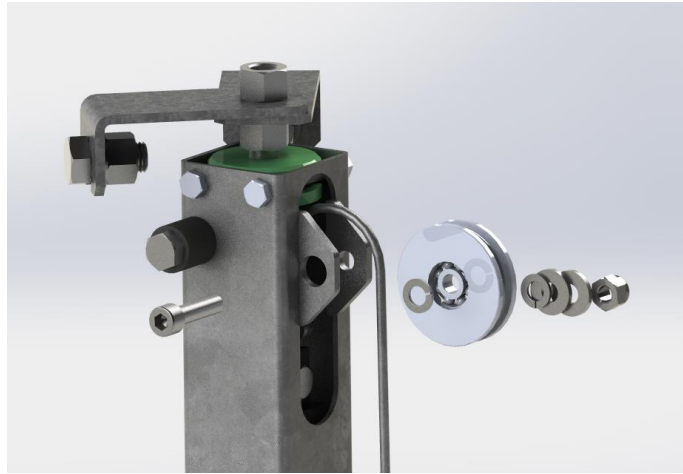

Fig 16. Disassemble the pulley

Step 3: Remove the wire rope

Using 16mm and 17mm sockets, remove the bolt which attaches the rope to the weight clevis.



Fig 17. Weight/rope bolt

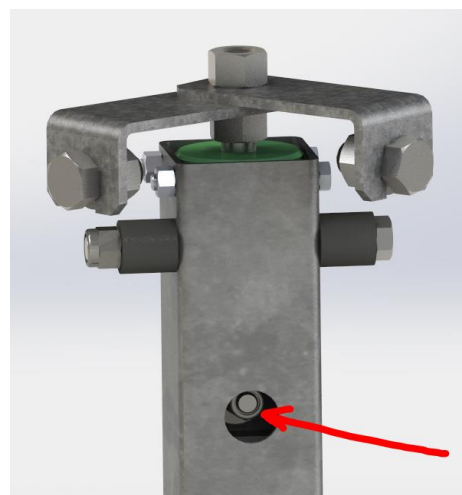

Fig 18. Weight/rope nut

Step 4: Attach the new rope and reassemble

If required, adjust the length of the new wire rope to be the same as the original. Replace the wire rope, reassembling all in reverse order.