

WELDING INDICATIONS

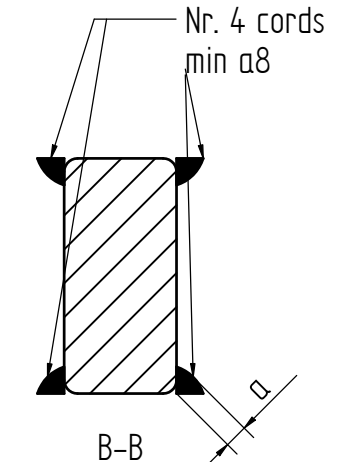

**BBM
7080
D 101
S 3600
YY-nn**

dimensions in mm
PAY ATTENTION:
between square brackets you will find
dimensions indicated into ISO 24347:2005

		FOLGIO sheet nr.1 A3	MATERIALE Material EN25CrMo4+QT	MASSA - mass 11,102 kg
TRATTAMENTO Process		PROGETTO project		SCALA scale
DENOMINAZIONE - Name Occh. sfera 80 piatto			CODICE - Part number 7080	
DIMENSIONI IN mm Dimensions in mm			Nome file: 7080-Adft	

QUESTO DISEGNO È DI PROPRIETÀ RISERVATA DELLA BBM SPA COSÌ COME LE INFORMAZIONI TECNICHE E COMMERCIALI IN ESSO CONTENUTE. SENZA IL CONSENSO SCRITTO DELLA BBM SPA, ESSO NON PUÒ ESSERE RIPRODOTTO, UTILIZZATO O TRASMESSO A TERZI TUTTO O IN PARTE.					This drawing is the confidential property of BBM SpA as also technical and commercial informations contained therein. Without prior written consent of BBM SpA it must not be copied, used or communicated to others wholly or in part.				
TOLLERANZE GENERALI SENZA INDICAZIONE / General tolerances unless specified					SUPERFICI GREZZE / rough surfaces NORMA / ref. norm UNI EN..... - GRADO /grade				
SUPERFICI LAVORATE / machined surfaces NORMA / ref. norm UNI EN 22768-1 - GRADO /grade m					DIMENSIONI IN mm Dimensions in mm				

ESPOSIZIONE	DATA	AUTORE	DESCRIZIONE	CHECKED BY
00	02/07/2018	A.S.	Nuovo	SIX